



**H.E.BURNS &
SONS Pty Ltd.**

**15 Welder RD
Sevenhills NSW 2147**

Phone: (02) 9624 8666
Fax: (02) 9624 8859
Email: Admin@stainlessgroup.com.au



**STAINLESS STEEL FIXINGS FOR
THIN VENEER STONE.**



**H.E.BURNS & SONS Pty Ltd.
15 WELDER RD
SEVENHILLS NSW 2147
TELEPHONE: (02) 9624 8666
Fax (02) 9624 8859**

This catalogue contains a few of the most widely used stainless steel and aluminum stone fixing elements by HEBurns & Sons. These fixing elements are predominantly intended for use in hand set thin stone veneer cladding systems, However they may be suitable for use in other cladding applications.

The range of variations possible with this fixings is unlimited, and modifications for particular projects can be accommodated to in most cases.

HEBurns & Sons Pty Ltd will exercise the degree of skills and care expected in customary practices and procedures during the manufacturing and supply of its products.

If you have any questions or requirement please do not hesitate in contacting our friendly team.

FIXING TYPE - I WIND LOAD ANCHOR

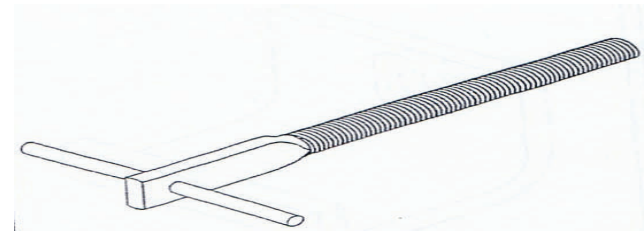

NOTES:

1. Rod and pin are stainless steel Grade 316.
2. Stone fixing pin supplied at required length.
3. Diameter of stone fixing pin can be varied.
4. All Dimensions in mm.

FIXING TYPE - K DEAD & WIND LOAD ANCHOR SINGLE TWO-SIDED PIN FIXING

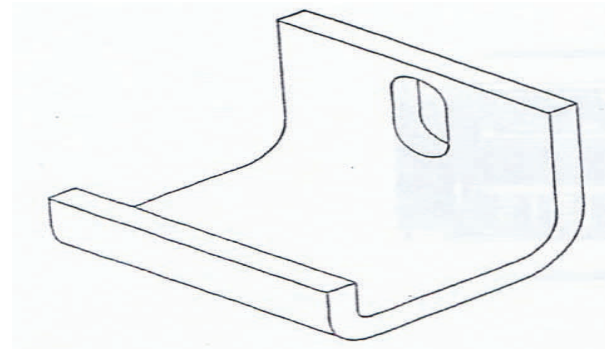

NOTES:

1. Angle is stainless steel Grade 316.
2. Bolt hole size will be dependent on bolt diameter.
3. All Dimensions in mm.

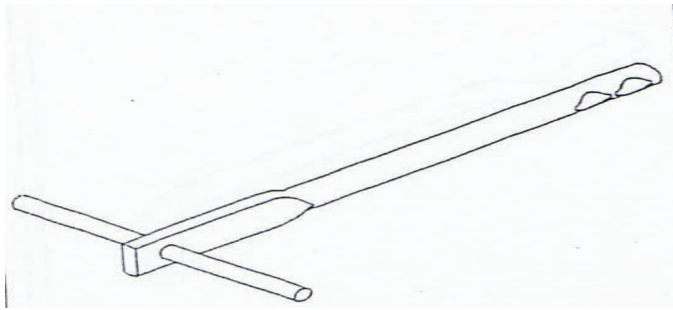
FIXING TYPE - G WIND LOAD ANCHOR**NOTES:**

1. Rod and pin are stainless steel Grade 316.
2. Stone fixing pin supplied at required length.
3. Diameter of stone fixing pin can be varied.
4. All Dimensions in mm.

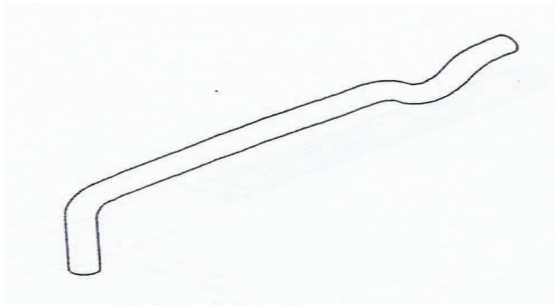
FIXING TYPE - H WIND LOAD ANCHOR**NOTES:**

1. Rod is stainless steel Grade 316.
2. Stone fixing Rod supplied at required length.
3. All Dimensions in mm.

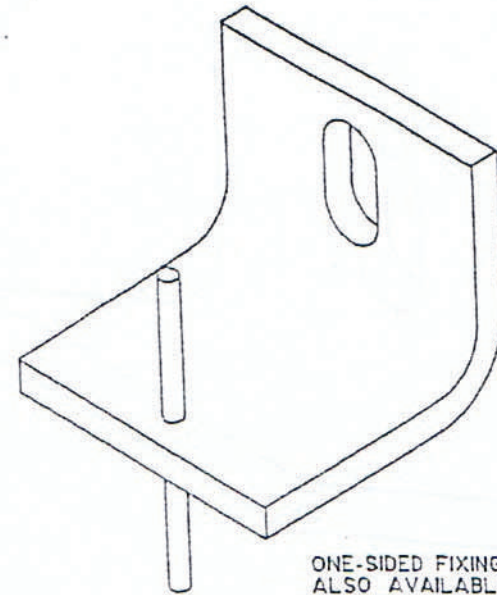
FIXING TYPE - A DEAD & WIND LOAD ANCHOR
SINGLE TWO-SIDED PIN FIXING**NOTES:**

1. Angle and pin are stainless steel Grade 316.
2. Bolt hole size will be dependent on bolt diameter.
3. Stone fixing pin supplied at required length.
4. Diameter of stone fixing pin can be varied.
5. All Dimensions in mm.

FIXING TYPE - B DEAD & WIND LOAD ANCHOR ADJUSTABLE ANGLE FIXING

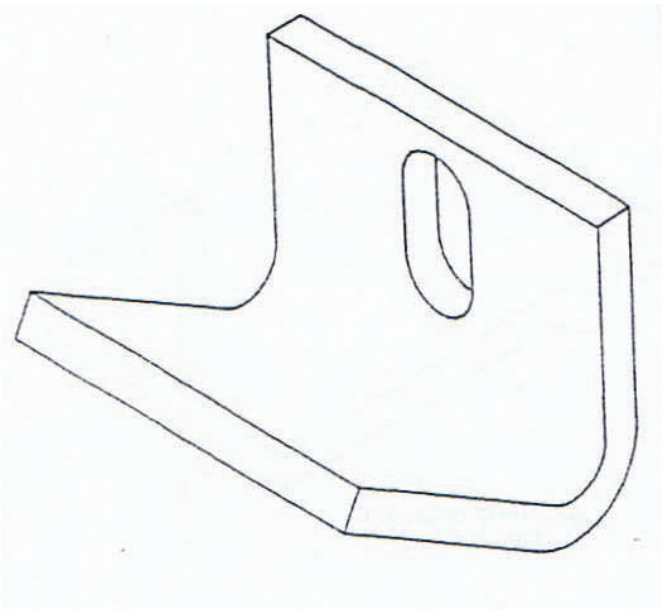

NOTES:

1. Angle is stainless steel Grade 316.
2. Bolt hole size will be dependent on bolt diameter.
3. Stone fixing pin supplied at required length.
4. Diameter of stone fixing pin can be varied.
5. All Dimensions in mm.

FIXING TYPE - C DEAD & WIND LOAD ANCHOR SINGLE TWO-SIDED PIN FIXING

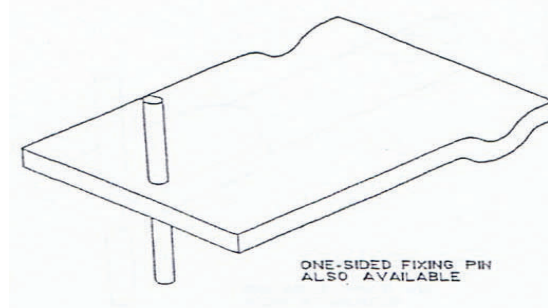

NOTES:

1. Plate and pin are stainless steel Grade 316.
2. Stone fixing pin supplied at required length.
3. Diameter of stone fixing pin can be varied.
4. All Dimensions in mm.

FIXING TYPE - F DEAD & WIND LOAD ANCHOR SINGLE TWO-SIDED PIN FIXING

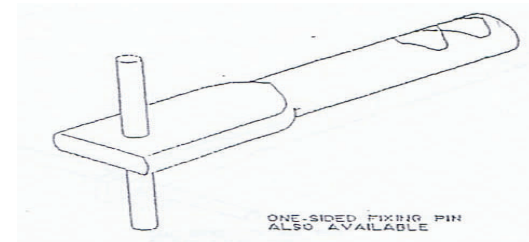

NOTES:

1. Rod and pin are stainless steel Grade 316.
2. Stone fixing pin supplied at required length.
3. Diameter of stone fixing pin can be varied.
4. Between 8-10-12 Diameter.
5. Standard stock.